

Válvula Tipo P (Passagem Angular) Atuador Normal Fechado

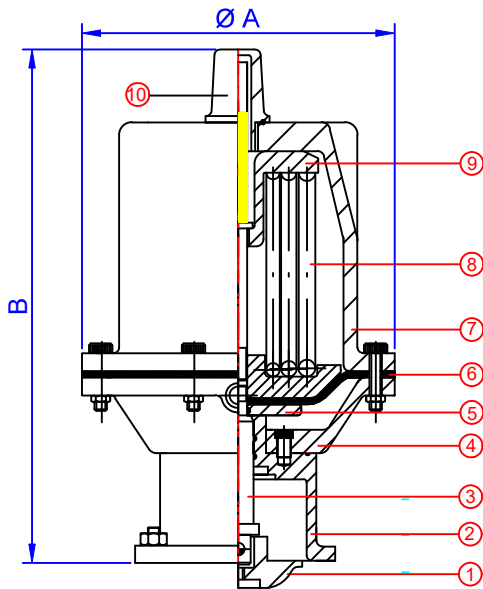

Pos.	Componente
1	Compressor
2	Tampa
3	Haste
4	Campânula Inferior
5	Prato do Diafragma
6	Diafragma do Comando
7	Campânula Superior
8	Mola
9	Apoio da Mola
10	Indicador Abertura

Modelo	Principais Dimensões																	
	IF-S113			IF-S170			IF-S266			IF-S330			IF-S370			IF-S600		
Bitola	1/2"	3/4"	1"	1"	1.1/4"	1.1/2"	2"	2"	2.1/2"	3"	4"	3"	4"	5"	4"	5"	6"	8"
ØA	113,0	113,0	113,0	170,0	170,0	170,0	170,0	266,0	266,0	266,0	266,0	336,0	336,0	336,0	370,0	370,0	370,0	600,0
B	221,0	230,0	238,0	270,0	276,0	282,0	295,0	380,0	395,0	405,0	454,0	442,0	455,0	471,0	530,0	570,0	585,0	1030,0

Pressão recomendada de operação em função da pressão de linha																			
Tamanho do Atuador	Bitola	Comb. Molas	Pressão de Linha (bar)																
			1	2	3	4	5	6	7	8	9	10							
Série 113	1/2"	1						3,0 Bar											
		2																	3,0 Bar
		3																	
	3/4"	1																	
		2	2,5 Bar																
		3						4,0 Bar											
Série 170	1"	1																	
		2																	
		3																	
	1"	1																	
		2																	
		3																	
Série 266	1.1/4"	1																	
		2																	
		3																	
	1.1/2"	1																	
		2																	
		3																	
Série 330	2"	1																	
		2																	
		3																	
	2"	1																	
		2																	
		3																	
Série 370	2.1/2"	1																	
		2																	
		3																	
	3"	1																	
		2																	
		3																	
Série 600	4"	1																	
		2																	
		3																	
	5"	1																	
		2																	
		3																	

Obs° - As conexões de ar comprimido para atuadores ID-170D a ID-370D são de 1/4" BSP e para atuadores ID-600D é 3/8" BSP

ATUADOR NORMAL FECHADO COM VOLANTE DE EMERGÊNCIA

Válvula Diafragma Tipo P (Passagem Angular)

Válvula Diafragma Tipo D (Passagem Retta)

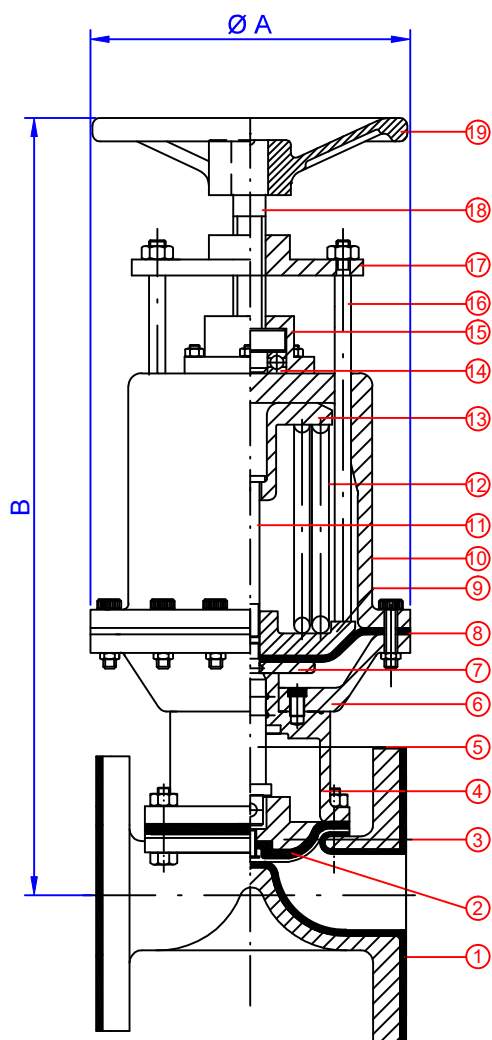

19	Volante
18	Haste do Volante
17	Guia do Tirante
16	Tirante
15	Mancal
14	Rolamento
13	Apoio Sup. Molas
12	Mola
11	Haste Superior
10	Campânula Superior
9	Apoio Inf. Molas
8	Diafragma do Comando
7	Prato do Diafragma
6	Campânula Inferior
5	Haste
4	Tampa
3	Compressor
2	Diafragma de Vedação
1	Corpo Revest. Ebonite
Pos.	Componente

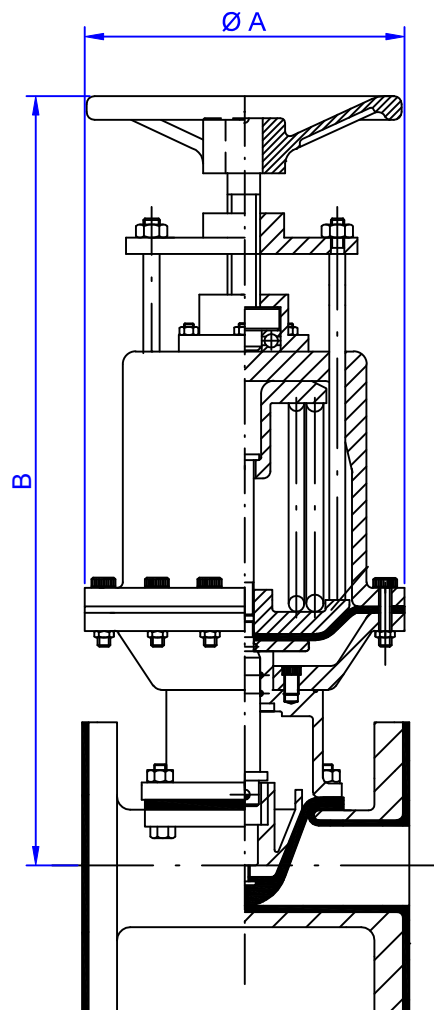

Válvula Diafragma Tipo P (Passagem Angular)

Principais Dimensões																		
Modelo	IF-S113			IF-S170				IF-S266				IF-S330		IF-S370		IF-S600		
Bitola	1/2"	3/4"	1"	1"	1.1/4"	1.1/2"	2"	2"	2.1/2"	3"	4"	3"	4"	5"	4"	5"	6"	8"
ØA	113,0	113,0	113,0	170,0	170,0	170,0	170,0	266,0	266,0	266,0	266,0	336,0	336,0	336,0	370,0	370,0	370,0	600,0
B	362,0	376,0	386,0	489,0	500,0	508,0	529,0	655,0	678,0	695,0	758,0	732,0	759,0	876,0	834,0	975,0	1007,0	1484,0

Válvula Diafragma Tipo D (Passagem Retta)

Principais Dimensões															
Modelo	ID-S170			ID-S266				ID-S330		ID-S370		ID-S600			
Bitola	1"	1.1/4"	1.1/2"	2"	2"	2.1/2"	3"	3"	4"	5"	4"	5"	6"	8"	
ØA	170,0	170,0	170,0	170,0	266,0	266,0	266,0	336,0	336,0	336,0	370,0	370,0	370,0	600,0	
B	506,0	506,0	506,0	531,0	638	638,0	702,0	742,0	764,0	872,0	832,0	992,0	1001,0	1380,0	